

CAVA CURVE LED

PENDANT DIRECT

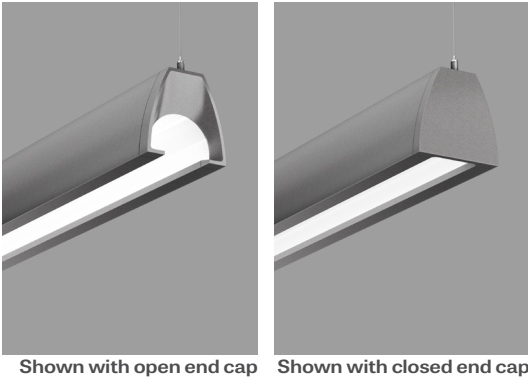

Shown with open end cap Shown with closed end cap

DESCRIPTION

Cava is a linear LED recessed, surface and pendant luminaire with a remarkably comfortable and surprising appearance. Using completely concealed and indirect LED arrays, Cava provides superior brightness control, while maintaining high efficacy by distributing light over the vaulted interior cavity of the luminaire. See separate spec sheets for other available design and mountings.

PROJECT: _____

TYPE: _____

NOTES: _____



SENSORS
For latest information on sensors, click [here](#).

ORDER GUIDE

up to 122 lm/w performance

| CAVCPD | | RLO | SW | | | |
|--|--|---|--|---|--|--|
| LUMINAIRE ID | END CAP | OPTIC | LIGHT SOURCE | CRI | LUMEN PACKAGES | COLOR TEMP. |
| CAVCPD - cava curve pendant direct | OP - open end cap CO - closed end cap | RLO - Reduced Luminance Optic | SW - Static white | 80 - 80CRI 90 - 90CRI | 350 - min. low output 350lm/ft 500 - medium output 500lm/ft 750 - max. high output 750lm/ft #### - other required lm/ft | 27 - 2700k 30 - 3000k 35 - 3500k 40 - 4000k |
| LUMINAIRE LENGTH | VOLTAGE | DRIVER | ELECTRICAL | MOUNTING | | |
| Standard sections - 2', 3', 4', 5', 8' & 12' For all other specify length #FT - nominal length in feet Continuous Run - for luminaires over 12' | 120 - 120V 277 - 277V UNV - 120V-277V 347 ¹ - 347V ¹ Available with D1 driver only. | D1 - 1% 0-10V DA ² - DALI LDE1 ² - Lutron Hi-Lume 1% Eco ² On-site commissioning is required. | 1 - 1 circuit +#EB - emergency battery (min 4' fixture, except Lutron) +#EM - emergency light circuit +#NL - night light circuit +GTD### - generator transfer device, 120V or 277V | 53WAC36 - power 5" + non power 3" white canopy (36" air craft cable) 55WSW18 - power 5" + non power 5" white canopy & stem (18" stem) For all other options refer to our Pendant Mounting Guide | | |
| FINISH | CONTROL ³ | CONNECTED CONTROLS ⁸ | | OPTIONS | | |
| W - matte white AL - aluminum B - matte black CF# - custom finish specify RAL# | STANDALONE CONTROLS ^{4,5} Specify the quantity (#) of sensors per fixture. #OMS ⁶ - Onboard Occupancy #OMS## ⁷ - Onboard Occupancy with bi-level dimming #ODS - Onboard Daylight #OCS - Onboard Occupancy & Daylight | LU - Lutron AWN - Lutron Athena Wireless Node RF Only AWNS - Lutron Athena Wireless Node Sensor | ENC - Encelium WL - Cooper Wavelinx AN - Acuity nLight CA - Casambi LG - Legrand | FU120 - Fuse120V FU277 - Fuse 277V TB# - T-bar caddy clip specify grid size TG# - Tegular caddy clip specify grid size ST - Screw Slots caddy clip CU - custom | | |
| NA - None | | | | | | |
| ³ Standalone and connected control options cannot be combined. | | ⁶ Fixture turns off when no occupancy. | | | | |
| ⁴ Available with D1 driver and 1 circuit options only. | | ⁷ Fixture dims to specified light level % (##). | | | | |
| ⁵ Minimum 4' per zone. Provide control zone length. | | ⁸ Consult factory for connected controls. | | | | |

CROSS SECTION

See page 2 for ordering code detailed information

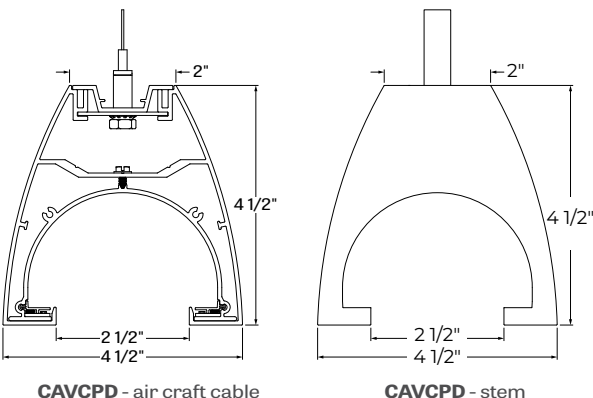

CAVCPD - air craft cable

CAVCPD - stem



OPTIC

REDUCED LUMINANCE OPTIC (RLO) - reduced Luminance Optic (RLO) consists of indirect-mounted LED arrays illuminating a vaulted reflector with a matte white finish greater than 95% reflectivity. The ultra-shallow arrays in RLO completely conceal the light source while evenly distributing brightness over the entire surface of the cavity using a combination of multiple reflective bounces and a very high diffuse reflectivity. Compared to diffusing optics, RLO reduces luminaire brightness due to the visible interior surface being larger than the aperture.

LIGHT SOURCE - LED

Custom linear array of mid-flux LED's are cartridge-mounted with quick-connect wiring to facilitate service and thermal management. Available in 2700K, 3000K, 3500K, and 4000K with a minimum 80 CRI and an option for 90 CRI with elevated R9 value. Color consistency maintained to within 3 SDCM. LEDs operated at reduced drive current to optimize efficacy and lumen maintenance. All LEDs have been tested in accordance with IESNA LM-80-08 and the results have shown L80 lumen maintenance greater than 60,000 hours. Absolute product photometry is measured and presented in accordance with IESNA LM-79, unless otherwise indicated.

PERFORMANCE PER 4' AT 4000K

| LED output | Color Temp | Watts | Nominal Delivered Lumens | Efficacy LPW |
|---------------|------------|-------|--------------------------|--------------|
| low output | 4000K | 11.5 | 1400 | 122 |
| medium output | 4000K | 17 | 2000 | 119 |
| high output | 4000K | 25 | 3000 | 119 |

LUMINAIRE LENGTH

Cava is made up of standard 2, 3, 4, 5, 8 and 12 foot sections that may be joined together to create longer continuous run lengths. Nominal run length must be noted in the product code. The minimum individual section available is 2 foot. All individual sections are joined together onsite using the joiner kits provided. LumenWerx offers joiner kits that are extremely simple to work with in the field and result in a fixture that appears virtually seamless with no light leak at any connection.

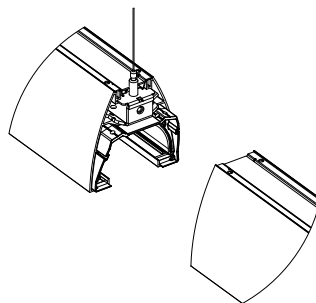

joining system for Cava curved

ELECTRICAL

Factory-set, adjustable output current LED driver with universal (120-277VAC) input. Dimmable from 100% to 1% with 0-10V dimming control. Rated life (90% survivorship) of 50,000 hours at 50°C max. ambient (and 70°C max. case) temperature. At maximum driver load: Efficiency > 84%, PF > 0.9, THD < 20%. Other specifiable options include Lutron Hi-Lume 1% Eco and DALI protocol drivers. All of our standard 0-10V drivers are NEMA 410 compliant.

EMERGENCY

Factory installed long life high temperature recyclable Ni-Cad battery pack with test switch and charge indicator, minimum of 90 minutes operation, up to 1000 lumens per 4ft (25°C) emergency lighting output. Recharge time of 24 hours.

MOUNTING OPTIONS

Fixtures can be pendant-mounted, using aircraft cables, or stem-mounted.

Unless otherwise specified, LumenWerx provides the following hardware:

For cable-mounted fixtures - 53WAC36 (5" white canopy for all power mounting point, 3" white canopy for non power mounting point, and a 36" cable)

For stem mounted fixtures - 55WSW18 (5" white canopy for all power mounting point, and non power mounting point, and a 18" white stem)

Caddy clips, if required specify under **OPTIONS**

[For all other options, see our website for a detailed Pendant Mounting Guide](#)

FINISH

Interior - 95%, reflective matte powder coated white paint

Exterior - matte white, matte black or aluminum powder coating.

Custom finishes are also available.

CONTROLS

Lumenwerx offers several options for integrating occupancy and daylight harvesting controls in our luminaires.

For latest information on sensors, click [here](#).



Standalone controls

An integrated standalone sensor controls the luminaire in which it is installed. Depending on the length, more than one sensor may be necessary and may control the entire luminaire, or just a section of it. These controls operate independently. Unless otherwise agreed, sensor location, blank size, and functionality of the sensor within the luminaire are selected by Lumenwerx. See client drawings for details.

Three types are available:

OMS: An integral Passive InfraRed (PIR) sensor turns luminaires on and off automatically with field-adjustable time out period. No wall control is used. Coverage pattern for large motion has a 12' diameter with the sensor mounted 8' above the floor; for small motion, the pattern has an 8' diameter. Typically, one sensor is required for every 10' of a continuous luminaire run.

ODS: An integral, daylight harvesting sensor with closed-loop operation dims the luminaire in which it is installed in order to compensate for available daylight. The sensor measures the combination of daylight and luminaire light reflected from horizontal surfaces below the luminaire. Initial onsite calibration is required via the use of provided remote control.

OCS: Both an occupancy and a daylight sensor are installed in the luminaire.

Connected controls

With connected controls, sensors or nodes installed in the luminaire form part of a larger control system infrastructure from manufacturers such as: Lutron, Encelium, Cooper Wavelinx, Acuity nLight, Casambi, Legrand, and others. These connected controls allow for a scalable system providing features like occupancy and daylight control, manual control, scheduling and configuration of various zones and scenes. Energy reporting and system monitoring are also possible. Specific capabilities depend on the control system being used.

Lumenwerx installs the components (sensors, nodes, power packs, etc) which may be supplied to us by a third party, or procured directly by Lumenwerx, depending on the control system manufacturer.

Lumenwerx is solely responsible for the installation of specified components; the controls manufacturer is responsible for performance of the control system.

To indicate a Lumenwerx luminaire with connected controls, identify the specific onsite control system to be integrated into the luminaires using the ordering code. Due to the diversity of components, you must contact factory to assure complete compatibility with intended control system and to fully specify the luminaire.

Complete control specifications, sensor/node/power pack layout, and narrative for the control system are required for Lumenwerx to create shop drawings and submittals.

CONSTRUCTION

Housing - Extruded Aluminum 0.075" nominal, matte white or aluminum powder coating.

Custom finishes are also available.

End cap - Die cast Aluminum (0.95" nominal)

Joiners - Die cast Aluminum (0.95" nominal)

Reflectors - Extruded Aluminum 0.07" nominal, 95% reflective matte white painted

Hanger - Chromed Griplock securely attached with spring steel hardware in end caps and/or joiners

Air craft cable suspension - 7x7 braids Aluminum air craft cable 0.06" thick

Stem - 0.5" diameter threaded steel tube matte white or aluminum powder coating. Custom finishes are also available

WEIGHT

Cava curved 4ft - 11.78lbs - 5.35kg

Cava curved 8ft - 22.91lbs - 10.4kg

Cava curved 12ft - 34.14lbs - 15.5kg

CERTIFICATION

ETL - Rated for indoor dry/damp locations. Conforms to UL Standard 1598 and certified to CAN/CSA Standard C22.2 No. 250.0.

WARRANTY

LumenWerx provides a five-year limited warranty of electrical and mechanical performance of the luminaires, including the LED boards, drivers, and auxiliary electronics. LumenWerx will repair or replace defective luminaires or components at our discretion, provided they have been installed and operated in accordance with our specifications. Other limitations apply, please refer to the full warranty on our website.

CAVA CURVE LED

PENDANT DIRECT



350 LUMEN AT 80CRI - LOW OUTPUT

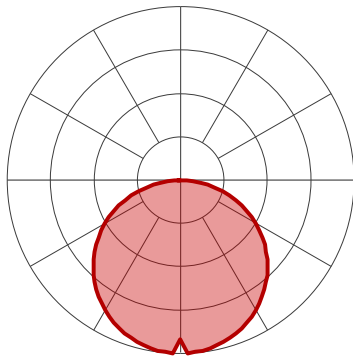

PERFORMANCE PER 4'

| LED output | Color Temp | Watts | Nominal Delivered Lumens | Efficacy LPW |
|------------|------------|-------|--------------------------|--------------|
| low output | 2700K | 12.5 | 1400 | 112 |
| low output | 3000K | 12 | 1400 | 116 |
| low output | 3500K | 12 | 1400 | 118 |
| low output | 4000K | 11.5 | 1400 | 122 |

500 LUMEN AT 80CRI - MEDIUM OUTPUT

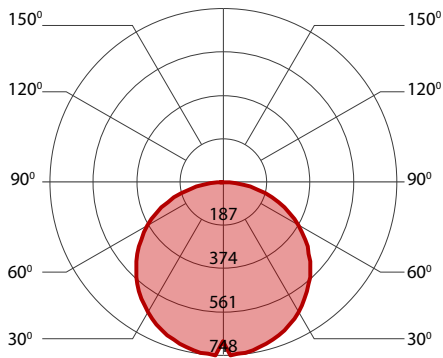

PERFORMANCE PER 4'

| LED output | Color Temp | Watts | Nominal Delivered Lumens | Efficacy LPW |
|---------------|------------|-------|--------------------------|--------------|
| medium output | 2700K | 18.5 | 2000 | 109 |
| medium output | 3000K | 17.5 | 2000 | 113 |
| medium output | 3500K | 17.5 | 2000 | 115 |
| medium output | 4000K | 17 | 2000 | 119 |

750 LUMEN AT 80CRI - HIGH OUTPUT

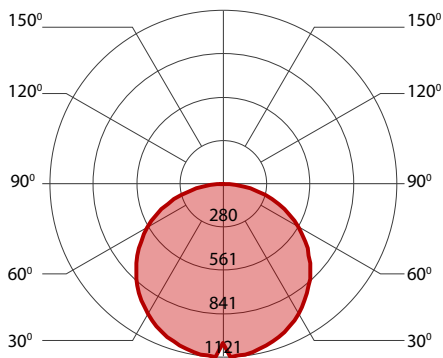

PERFORMANCE PER 4'

| LED output | Color Temp | Watts | Nominal Delivered Lumens | Efficacy LPW |
|-------------|------------|-------|--------------------------|--------------|
| high output | 2700K | 27.5 | 3000 | 110 |
| high output | 3000K | 26.5 | 3000 | 113 |
| high output | 3500K | 26 | 3000 | 116 |
| high output | 4000K | 25 | 3000 | 119 |