

Arro

TRIANGULAR FORM. LINEAR FREEDOM.





Arro Collection

Visual interest and versatility come together in Arro pendants, easily recognizable by their triangular prism form. Offered in compact 2" and 4" widths, each Arro fixture is equipped with our proprietary High-Efficiency Lambertian Optic (HLO) providing Direct or Direct/Indirect light distribution at up to an impressive 119 lm/W.

Arro's design encourages play. Not only can Arro fixtures be installed as continuous linear runs, but they can also be joined to form patterns, thereby acting as both an architectural and a decorative element. Also fun are Arro's pre-assembled triangle, rectangle, and square forms shipped directly from factory, custom-sized shapes are also available.

For noise control, our Arro 4 Acoustix luminaire is fitted with sound-absorbing material. Offered in a range of colors, Arro 4 Acoustix reinforces the collection's appeal as good-looking and efficient lighting solutions. Adaptable to a wide variety of applications, Arro 4 Acoustix helps to dampen reverberation in a room.

2 Widths

UP TO
119 lm/W

Pre-Assembled Shapes

SOUND DAMPENING
Arro 4 Acoustix

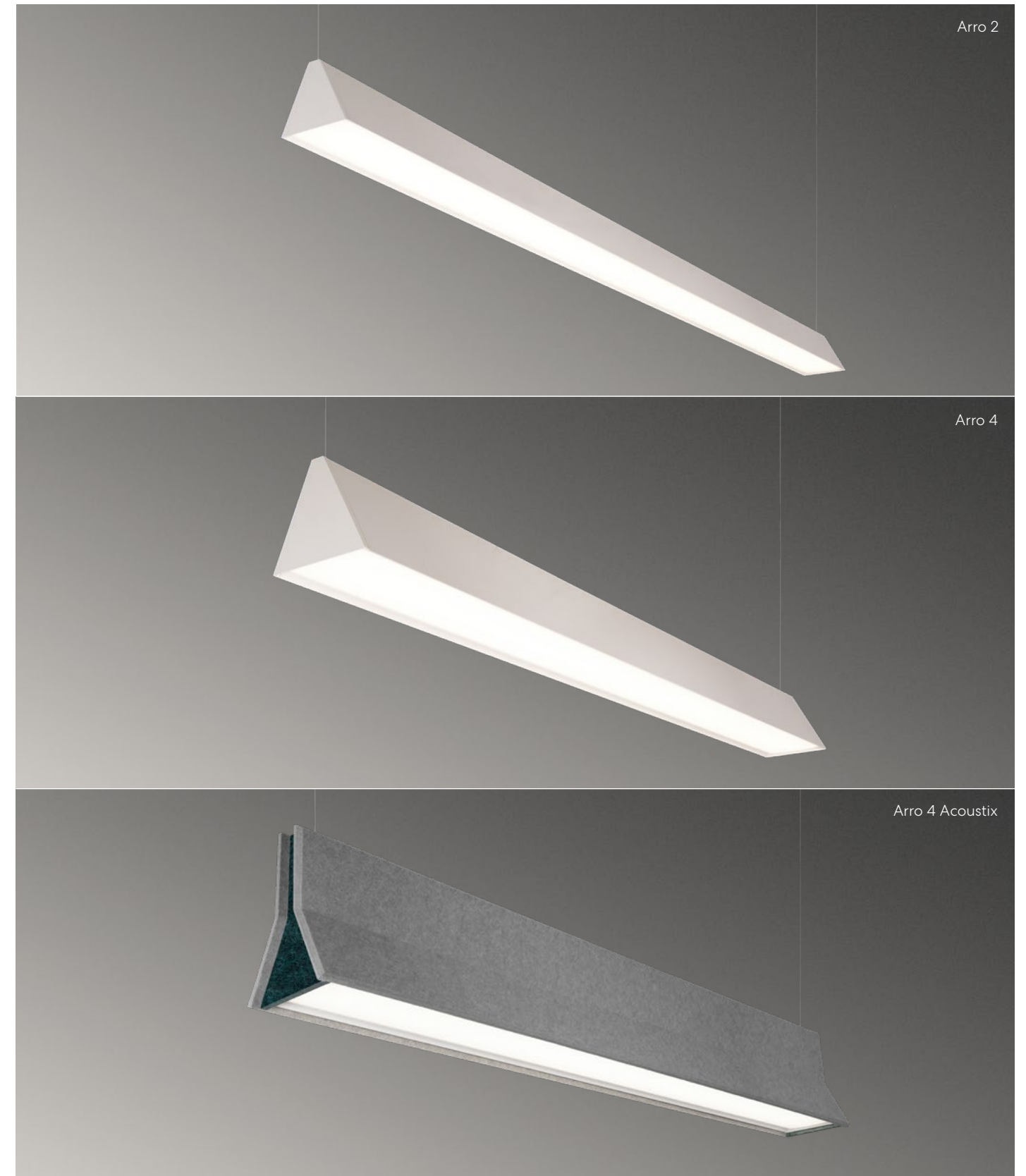



Arro 2

Optics & Performance

Despite its compact 2" base and height, Arro 2 is big with offerings including Direct distribution, continuous-run capacity with maximum 8' sections, great pattern potential, three stylish forms (rectangle, square, and triangle), and both X and Y spokes.

Esthetically, the restrained elegance of Arro 2 allows it to enter any environment with ease, for example, as a solo fixture in a posh new build, or by contrast, in a pairing with Arro 4 or Arro 4 Acoustix in a more traditional setting characterized by antiques.

5 Shapes

UP TO

750 lm/ft

UP TO

107 lm/W

UP TO

95+ CRI

PROFILE AND DISTRIBUTION

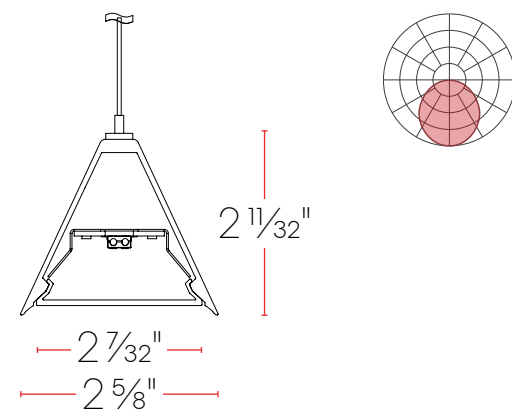



Arro 2 Y Spoke shapes featured with a linear Arro 2 over the reception desk and Arro 4 in the boardroom



Elegant form
meets everyday
function



Overview

Arro 2

DISTRIBUTION

Direct

COLOR RENDERING OPTIONS

80+, 90+, 95+

MOUNTING

Pendant

SHAPES

Triangle
Square
Rectangle
X-Spoke
Y-Spoke



SIZE

2⁵/₈" x 2¹/₃₂"

FINISHES

- Matte White
- Matte Black
- Custom RAL

COLOR TEMPERATURES

- 2700K  Sola
- 3000K  Duo
- 3500K  Full Spectrum LED
- 4000K



Arro 2 end caps offer crisp lines to define the prism



Arro 4 Direct/Indirect
Distribution



Arro 4

Optics & Performance

With its 4" base, Arro 4 features Direct and Direct/Indirect distribution options, as well as our HLO for smooth illumination, and delivers a supreme efficacy of up to 101 lm/W. As with Arro 2, Arro 4 comes in a variety of pre-assembled forms—squares, triangles, rectangles, and X and Y spokes—and can also be continuously run, mounted, and mitered into patterns. This versatility makes it a natural choice for those with a keen eye for cohesive design.

PROFILE AND DISTRIBUTION

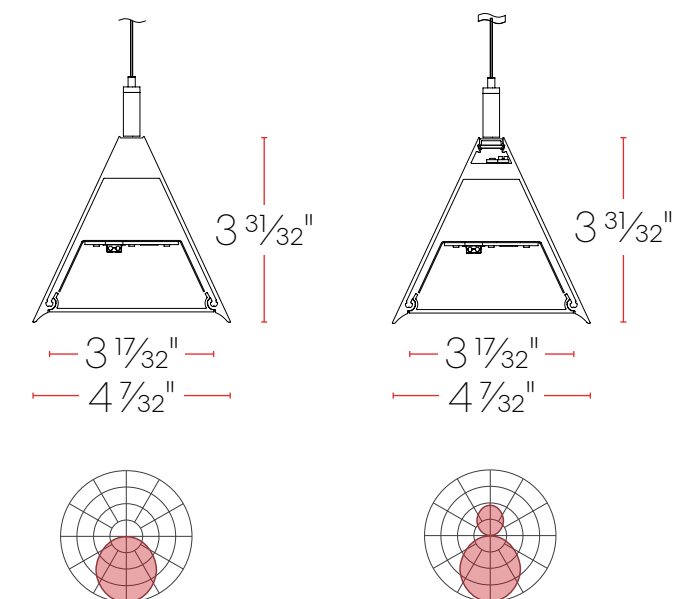



Overview

Arro 4

DISTRIBUTION

Direct
Direct/Indirect

COLOR RENDERING OPTIONS

80+, 90+, 95+

MOUNTING

Pendant

SHAPES

Triangle
Square
Rectangle
X-Spoke
Y-Spoke



SIZE

4⁷/₃₂" x 3³¹/₃₂"

FINISHES

- Matte White
- Matte Black
- Custom RAL

COLOR TEMPERATURES

- 2700K  Sola
- 3000K  Duo
- 3500K  Full Spectrum LED
- 4000K



Arro 4 offers both Direct and Indirect distribution with impeccable performance.



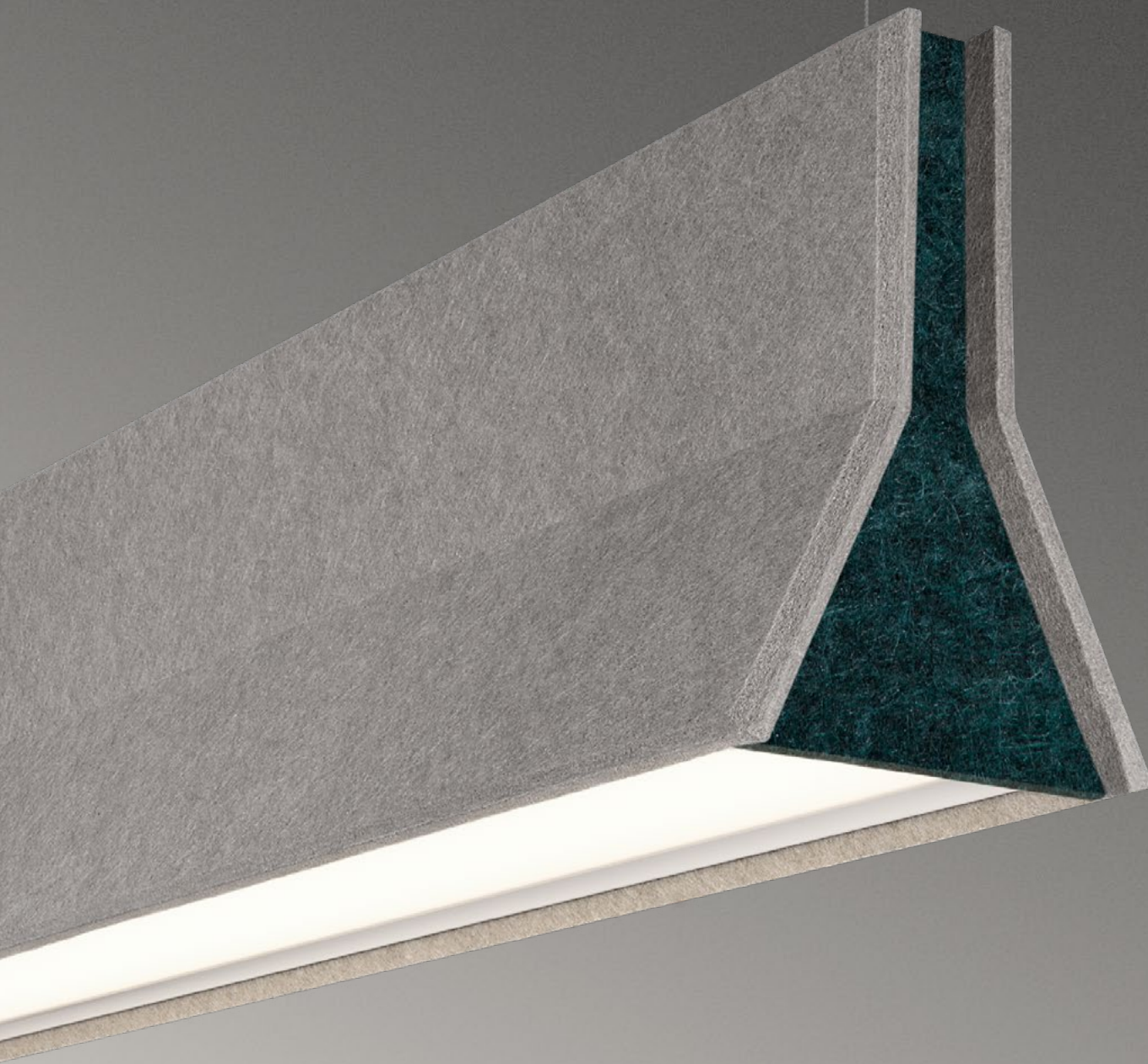

Arro 4 Acoustix

Arro 4 Acoustix delivers the same great performance as Arro 4 (up to 119 lm/W) but is fitted with superb acoustic damping technology. Offered in 4', 6', 8', 10', and 12' lengths with 10 standard and 19 premium color options, Arro 4 Acoustix features an elegant end cap detail, with sides extending beyond the inset end piece. Match the sides to the ends or choose a different color.

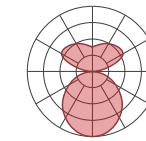

UP TO
1850 lm/ft

UP TO
119 lm/W

UP TO
+95 CRI

Direct
Direct/Indirect

Declare Label





The Arro 4 Acoustix in Cloudy and Lichen **completes** the space, balancing color, light, scale, and proportion.



Overview

Arro 4 Acoustix

DISTRIBUTION

Direct
Direct/Indirect

COLOR RENDERING OPTIONS



80+, 90+, 95+

LENGTHS

4 ft, 6 ft, 8 ft, 10 ft, 12 ft

COLOR TEMPERATURES

- 2700K
- 3000K
- 3500K
- 4000K

-  Sola
-  Duo

OPTIC DIRECT

High Efficiency
Lambertian Optic

OPTIC INDIRECT

Widespread Indirect Optic

STANDARD COLORS

- Frost White
- Lavender
- Fog
- Latte
- True Black
- Iron
- Plum
- Midnight Blue
- Cherry
- Forest Green

PREMIUM COLORS

- Blush
- Greige
- Charcoal
- Ivory
- Espresso
- Navy
- Café
- Blueberry
- Sky
- Lichen
- Orange
- Paprika
- Lime
- Graphite
- Lemon
- Cloudy
- Carbon
- Evergreen
- Steel

MADERA COLORS

- Natural Oak
- Teak
- Beech
- Grey Ash



ARRO COLLECTION
BROCHURE



ARRO COLLECTION
ONLINE

 **Lumenwerx**

ALWAYS LIGHT
RIGHT

lumenwerx.com
R.03.2026