

MINEAR RING

Pendant - Round Canopy Driver Box (RCD) - Single Canopy





INSTALLATION INSTRUCTIONS

 This product must be installed in accordance with the National Electrical Code and all applicable local codes, by a person familiar with the construction and operation of the product, and the hazards involved. Proper grounding is required for safety.

Ce produit doit être installé suivant le code national de l'électricité, ainsi que tous les codes locaux applicables, par une personne familière avec la construction et le fonctionnement du produit, ainsi que tous les risques qui y sont associés. La mise à terre électrique est obligatoire pour la sécurité.

 Disconnect power before installation or servicing.

 Do not cover the light element lens or heatsink with any materials or adhesive tapes when the fixture is powered.

 Handle the LED cartridge carefully during removal and installation. Tools must not touch the LED chips. Contact may result in damage and LED failure.

 Wire dimming conductors as Class 1.

 A luminaire with more than one power supply connection means shall be connected to only one branch circuit.

 For luminaires specified as recessed, clearance between the sides of the luminaire and parts of the building must be 1/2" minimum; clearance to insulating materials to be 3" minimum, unless luminaire is IC rated.

 For luminaires installed in wet locations, properly seal all mounting and electrical points.

 Warranty claims will not be accepted if incorrect driver or light element is used.

MINEAR RING

Pendant - Round Canopy Driver Box (RCD) - Single Canopy



INSTALLATION INSTRUCTIONS

POC
POWER-OVER-AIRCRAFT CABLE

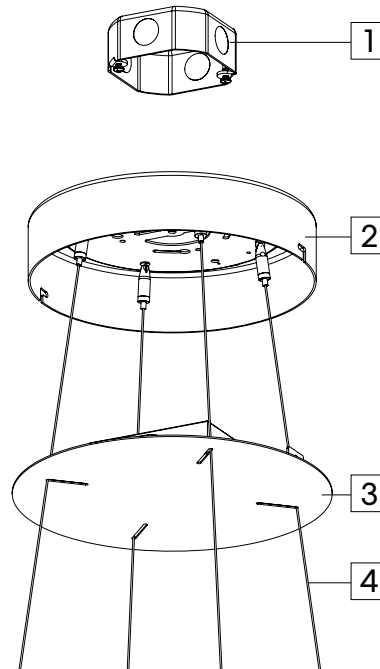

MINEAR RING

Pendant - Round Canopy Driver Box (RCD) - Single Canopy



POC (POWER-OVER-AIRCRAFT CABLE)

1 PREPARE MOUNTING POINTS.

Slightly loosen the screws [A] on the side of the canopy [B]. Remove the canopy plate [C].

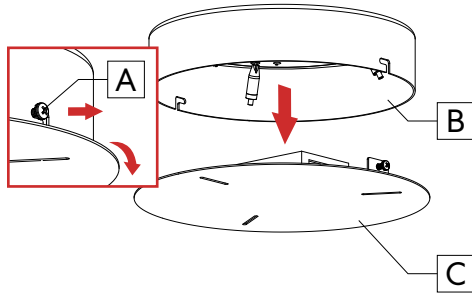

Fix the canopy [B] on the junction box [D].

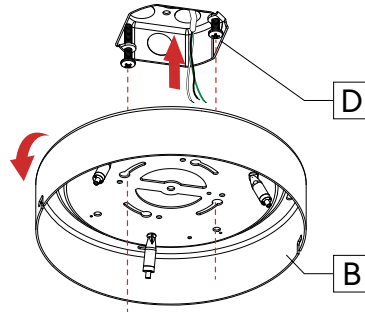

Use the canopy [B] as a model to mark 4 holes.

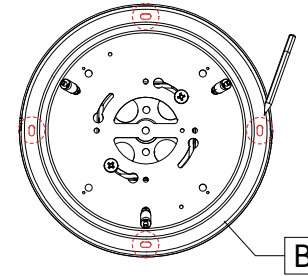

Remove the canopy. Drill holes (Ø 1/4") following the red marks. Install #8 drywall anchors [E].

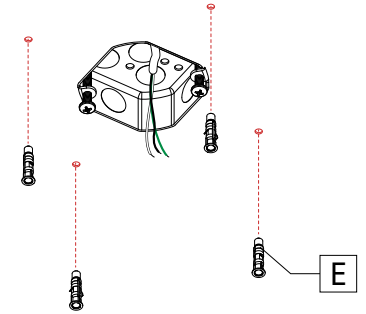

2 FIX CANOPY TO CEILING.

Tighten the two screws [F] to secure the canopy [B] to the junction box.

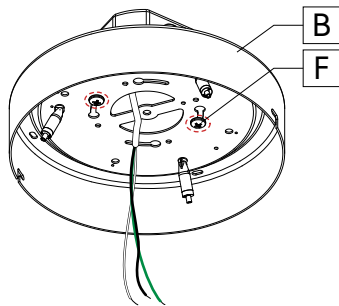

Use #8 screws [G] to fasten the canopy [B] to the ceiling.

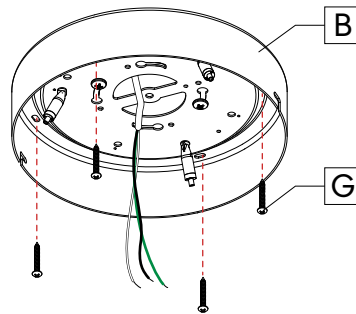

3 INSTALL AIRCRAFT CABLES.

Pass all aircraft cables [H] through the canopy plate [C]. Insert them into the griplocks [I]. Adjust the cables by pushing the feeder tube [I]. Cut the excess cables with an aircraft cable cutter [J].

Note: Height adjustment of the fixture must be done at this step. Leave POC (power-over-aircraft cable) length of 1.5" to make the connection inside the canopy. Number of aircraft cables may vary.

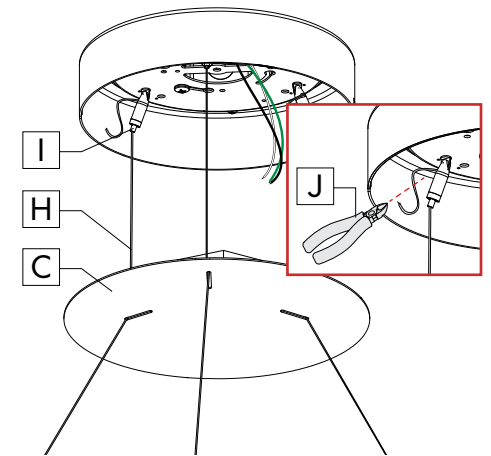

MINEAR RING

Pendant - Round Canopy Driver Box (RCD) - Single Canopy



POC (POWER-OVER-AIRCRAFT CABLE)

4 MAKE ELECTRICAL CONNECTIONS.

Make electrical connections between the driver [K] and the main power [L] with wire nuts [M] (by others).

Note: Connect the green wire to your ground wire. Make sure to have a steady hold of the fixture. So, it is never hanging loosely from POC (power-over-aircraft cable) if installation is not complete.

Note: Number of wires may vary.

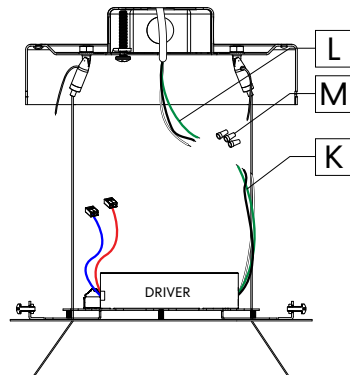

Make electrical connections between POC (power-over-aircraft cable) [N] and the driver [O].

Note: Make sure that you are connecting the negative (-) POC (as marked on the fixture with blue color and a label) to your negative wire and the positive (+) POC (as marked on the fixture with red color and a label) to your positive wire.

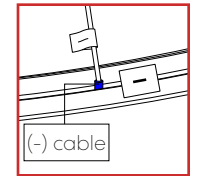
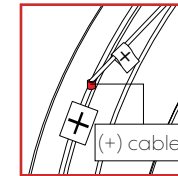
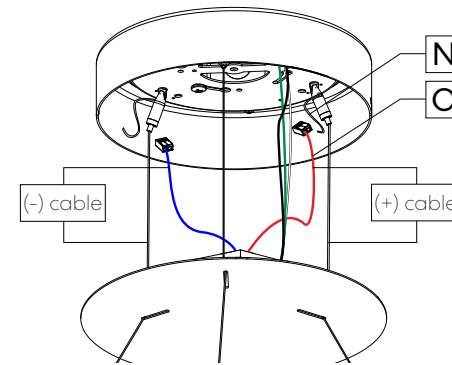

5 REINSTALL CANOPY PLATE.

Organise the wires that will be placed inside the canopy. Make sure that the low voltage (+) and (-) are more than 1" away from the branch circuit.

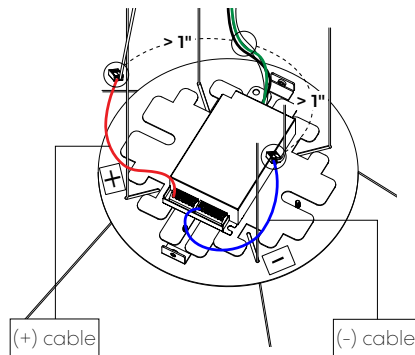

Put the canopy plate [C] back in place.

Secure the canopy plate [C] onto the canopy [B] by tightening the two screws [A] on the sides.

Cut the labels [P] off the wires.

