

IMPORTANT: Installation instructions are shown with Nova and applies to Nova and Vega fixtures

NOTE: Wire dimming conductors as Class 1

1 SINGLE FIXTURE

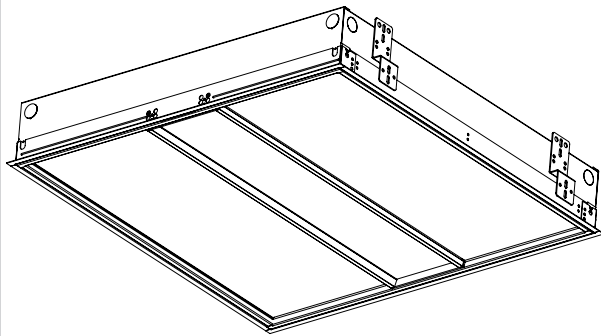

Make sure the power to the fixture is turned off.

2

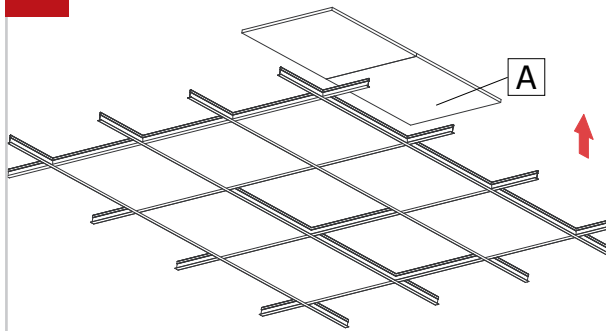

Remove ceiling tiles (A) where the fixture will be installed and adjacent tiles for easy access during installation.

3

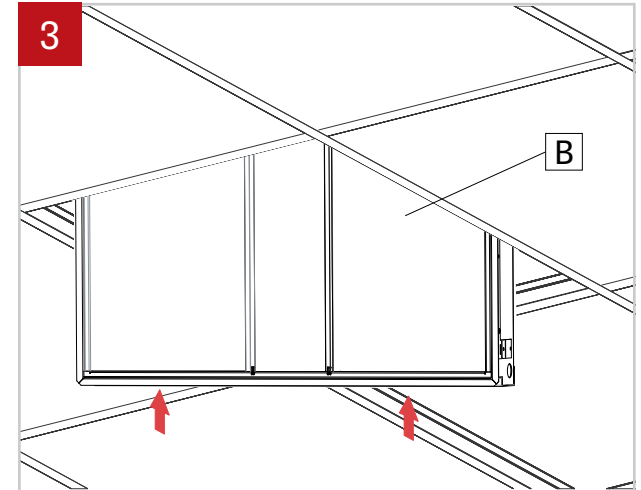

Insert the fixture (B) above the ceiling grid as shown.

4

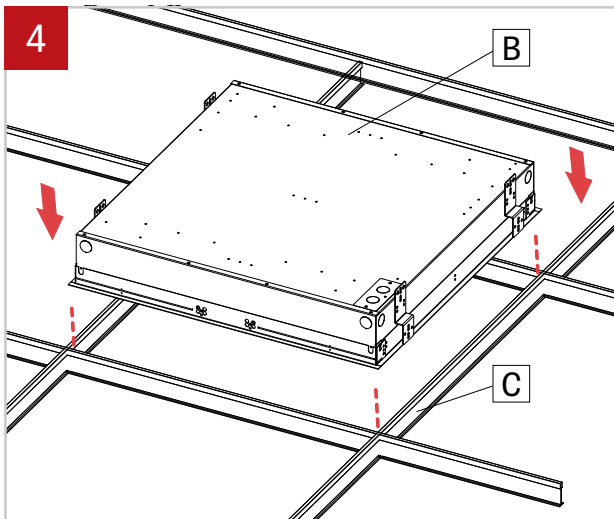

Lower the fixture (B) onto the T-bar grid (C).

5

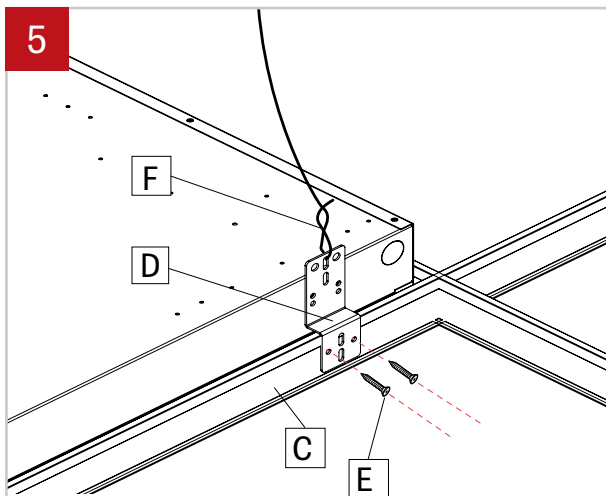

Secure the T-bar brackets (D) to the T-bars (C) with screws (E) (by others). For additional safety, a security wire (F) can be attached from the tabs.

6

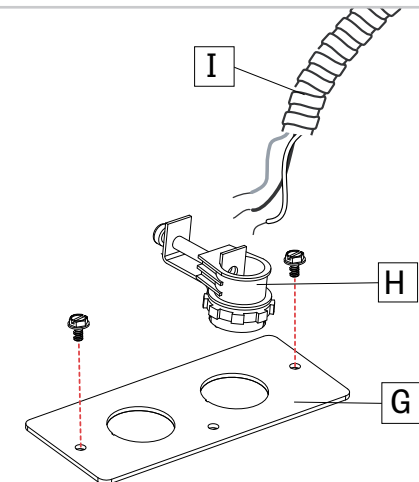

Remove power plate (G) from fixture and install BX connector (H) (by other) and BX cable (I) (by other) through the power plate. Tighten BX connector (H) screw.

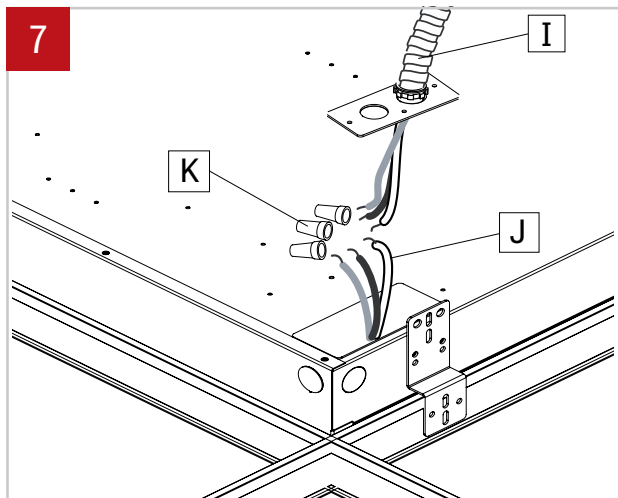

7 Connect cables from the BX cable (I) to the fixture driver cables (J) using wire nuts (K) (by others). Ensure connections comply with local and national electrical codes.

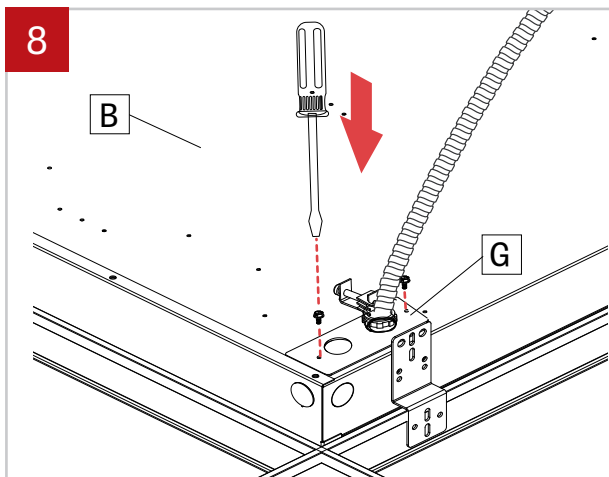

8 Push connected wires inside the fixture. Reinstall power plate (G) onto fixture (B) by refastening screws to power plate (G) and fixture (B).

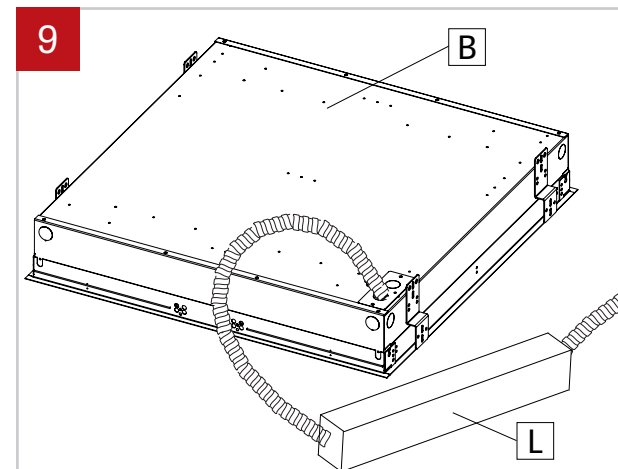

9 Place remote battery pack (L) not further than 50' from the fixture (B) (for an 18 gauge wire).

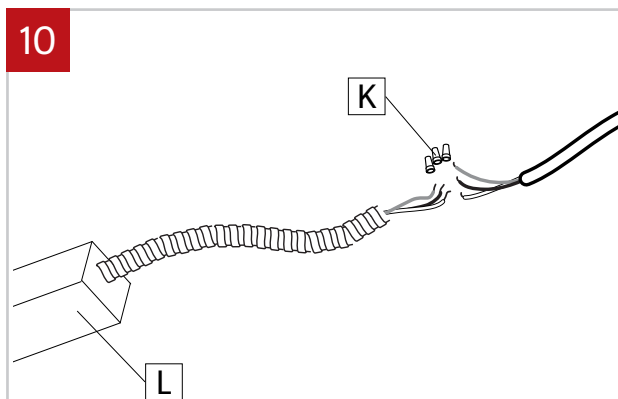

10 Connect remote battery pack (L) to the building's power feed using wire nuts (K) (by others).

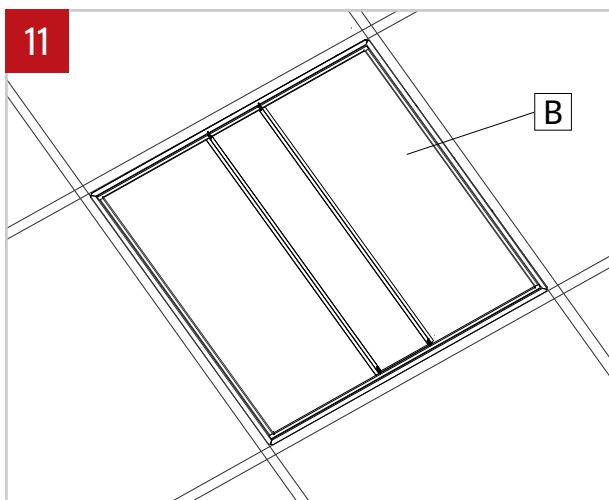

11 Power to the fixture (B) can now be safely turned on.