

SHALO ULTRA 2 - 3 - 5

Surface - Wood slat



 This product must be installed in accordance with the National Electrical Code and all applicable local codes, by a person familiar with the construction and operation of the product, and the hazards involved. Proper grounding is required for safety.

Ce produit doit être installé suivant le code national de l'électricité, ainsi que tous les codes locaux applicables, par une personne familière avec la construction et le fonctionnement du produit, ainsi que tous les risques qui y sont associés. La mise à terre électrique est obligatoire pour la sécurité.

 Wire dimming conductors as Class 1.

 For electrical connections, please refer to the [wiring diagram guide](#).



 For remote driver box, please refer to the [remote driver installation sheet](#) for more information.

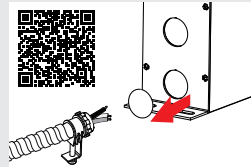

SINGLE FIXTURE

1 INSTALL MOUNTING BRACKETS.

CAUTION: Make sure the electrical power is turned off.

Locate the T-Bar [A] support and gently drop the mounting brackets [B] on it.

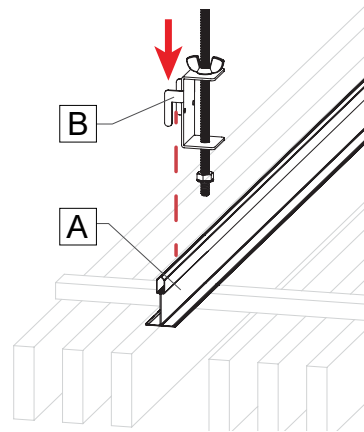

2 LOCATE THE MOUNTING BRACKETS.

Position the mounting brackets [B] on the T-bar [A], in the appropriate locations.

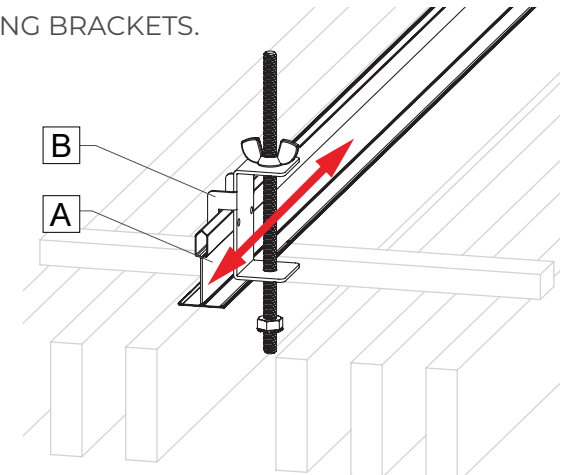

3 REMOVE CARTRIDGE.

Remove the cartridge [C] retained by safety cables [D] by using the provided tool [E].

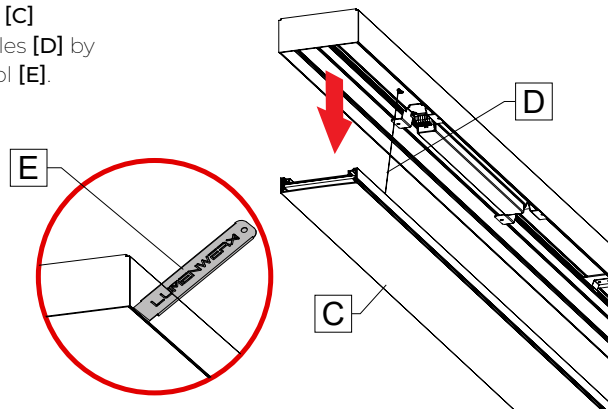

4 FASTEN FIXTURE.

Fasten the fixture to the threaded rods [F] on the mounting bracket by using washers [G] and nuts [H].

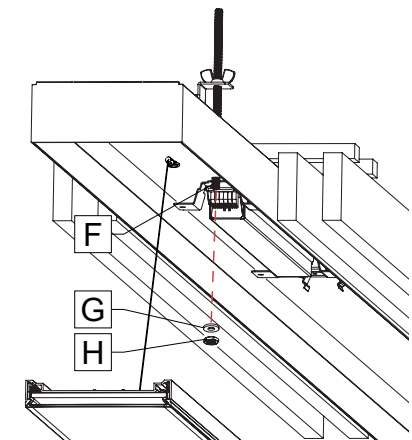
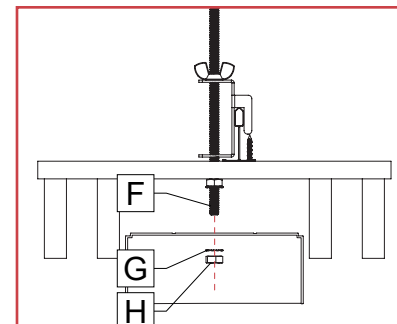

SHALO ULTRA 2 - 3 - 5

Surface - Wood slat



5 SECURE THE MOUNTING BRACKETS.

Secure the mounting brackets [B] by tightening screws [I] on the brackets.

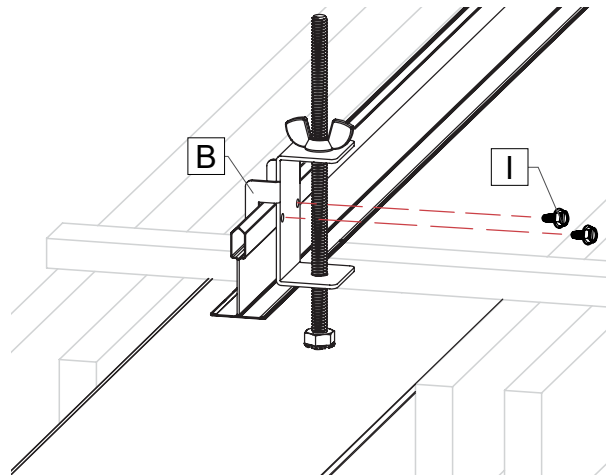

6 ADJUST THE FIXTURE.

Adjust the fixture's [J] height by turning the butterfly nut [K].

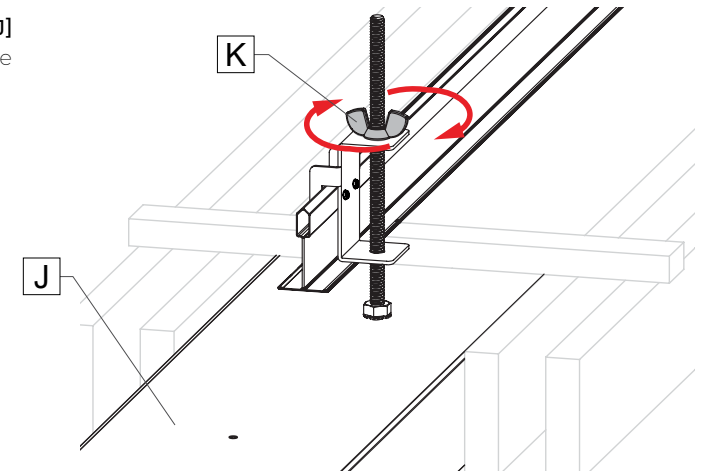

7 MAKE ELECTRICAL CONNECTIONS.

INTEGRAL DRIVER

Pass the main AC power cable [L] (by others) through the power plate [M] and install it.

Make electrical connections between the main power cables [L] and fixture cable [N] using wire nuts [O] (by others).

NOTE: Number of wires may vary.

WARNING: A luminaire with more than one power supply connection means shall be connected to only one branch circuit.

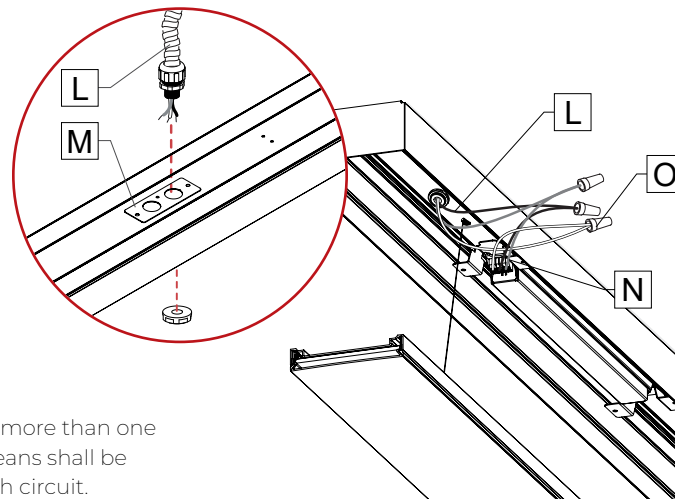

REMOTE DRIVER

Connect the main AC power cable to the remote driver box.

Then, connect the remote driver box DC cable [P] to the fixture using the provided wire harness [Q].

NOTE: A jumper cable (by others) might be necessary between the remote driver box and the fixture.



For remote driver box, please refer to the [remote driver installation sheet](#) for more information.

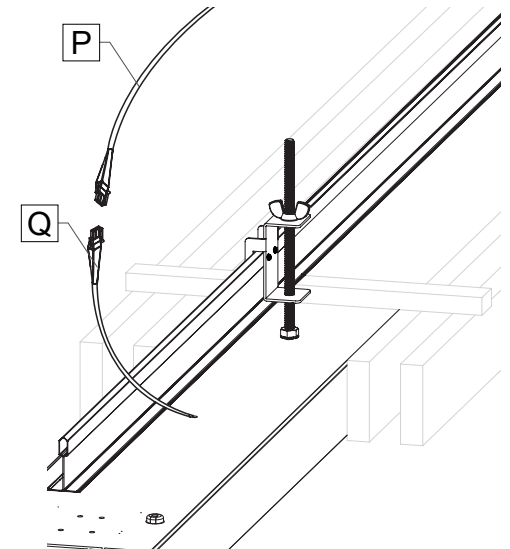

8 REINSTALL CARTRIDGE.



SHALO ULTRA 2 - 3 - 5

Surface - Wood slat

CONTINUOUS RUN

1 FOR A CONTINUOUS RUN, FOLLOW STEPS **1** TO **3** FROM THE SINGLE UNIT SECTION FOR ALL THE FIXTURES IN THE RUN, THEN:

2 FOLLOW STEPS **4** TO **7** FROM THE SINGLE UNIT SECTION FOR THE FIRST FIXTURE, THEN:

3 FIX THE NEXT FIXTURE TO THE MOUNTING BRACKET.

Fasten the fixture to the threaded rod **[F]** on the mounting bracket by using washers **[G]** and nuts **[H]**.

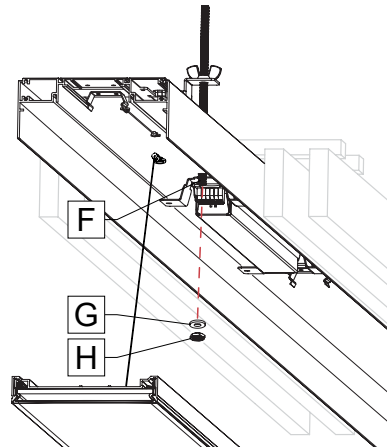
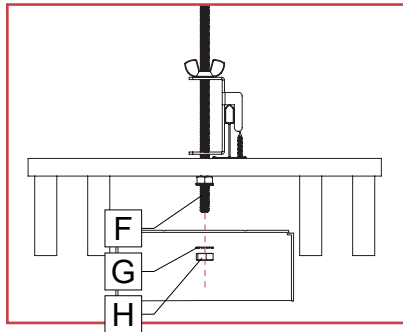

4 CONNECT AND JOIN FIXTURES.

Join the fixtures with the screw **[R]** to pull the fixtures together. Connect wires between joining fixtures using quick connectors **[S]**. Push wires inside the fixture.

NOTE: Number of wires may vary.

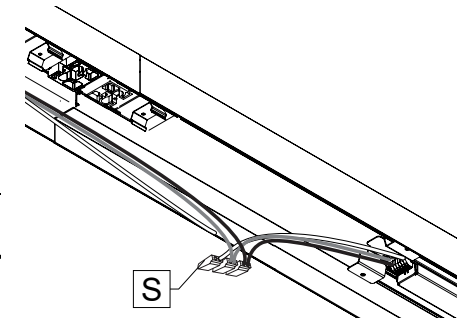
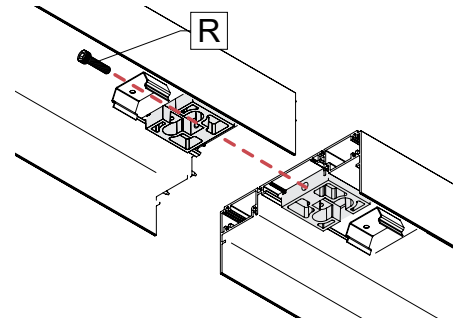

5 REPEAT STEPS **3** TO **4** FOR ALL FIXTURES IN THE RUN.

6 REINSTALL CARTRIDGES.

Reinstall the cartridges **[C]** back in place.

