

TOGO ACOUSTIX

Pendant - Remote Driver Box (RDB) - Multiple Canopies



INSTALLATION INSTRUCTIONS

! This product must be installed in accordance with the National Electrical Code and all applicable local codes, by a person familiar with the construction and operation of the product, and the hazards involved. Proper grounding is required for safety.

Ce produit doit être installé suivant le code national de l'électricité, ainsi que tous les codes locaux applicables, par une personne familière avec la construction et le fonctionnement du produit, ainsi que tous les risques qui y sont associés. La mise à terre électrique est obligatoire pour la sécurité.

! Disconnect power before installation or servicing.

! Wire dimming conductors as Class 1.

! A luminaire with more than one power supply connection means shall be connected to only one branch circuit.

! For electrical connections, please refer to the [wiring diagram guide](#).

! For remote driver box installation instructions, please refer to the [remote driver installation sheet](#).



POC POWER-OVER-AIRCRAFT CABLE

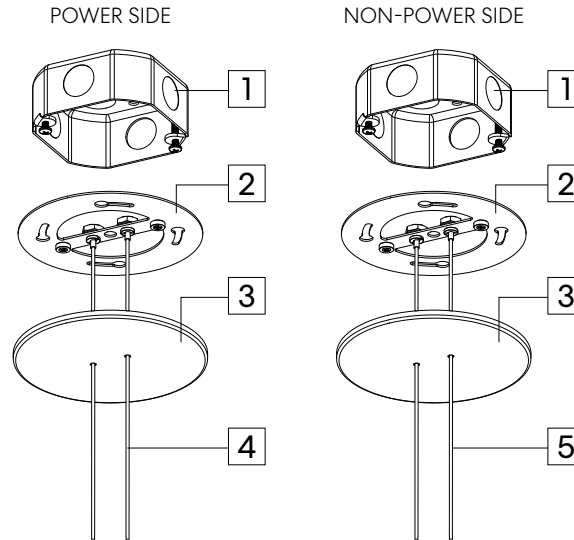

AC AIRCRAFT CABLE

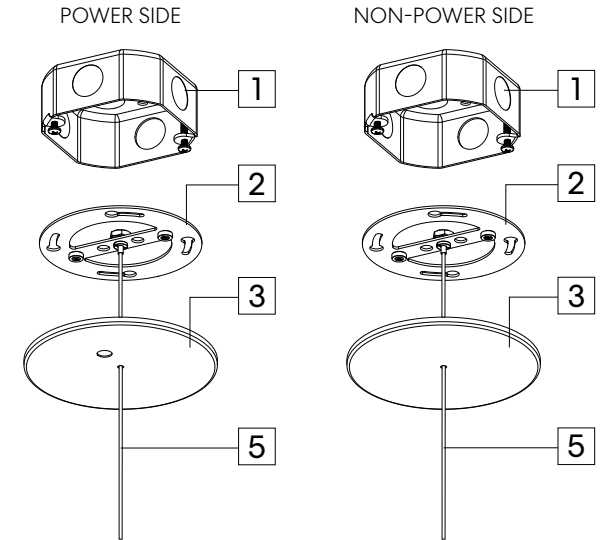

INDEX

POC.....	P2
Aircraft cable.....	P4

ITEMS LIST

1	Standard J-box (by others)
2	Mounting plate
3	Flat round canopy
4	Power-over-aircraft cable
5	Aircraft cable

TOOLS REQUIRED

- Phillips screwdriver
- Aircraft cable cutter
- Scissors (for POC)



TOGO ACOUSTIX

Pendant - Remote Driver Box (RDB) - Multiple Canopies



POC (POWER-OVER-AIRCRAFT CABLE)

POWER SIDE

1 INSTALL AIRCRAFT CABLES.

Install and reinforce J-box to ceiling structure. Separate the canopy [A] from the mounting plate [B].

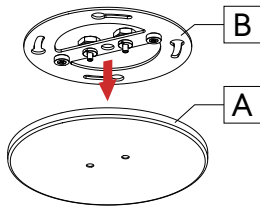

Pass the aircraft cables [C] through the canopy [A]. Insert them into the griplocks [D] then adjust the cables [C] by pushing the feeder tube [D].

Note: Make sure to have a steady hold of the fixture. It should never hang loosely from the POC (power-over-aircraft cable) if the installation is not complete.

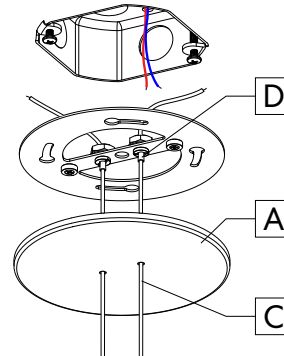

Pull the aircraft cables [C] and remote driver feed [E] out through the mounting plate [B] to make easy electrical connections.

Note: Height adjustment of the fixture must be done at this step.

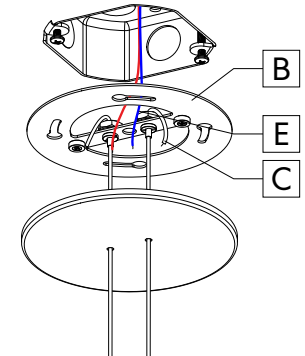

2 FIX MOUNTING PLATE TO CEILING.

Mount and turn the mounting plate [B] to place on the junction box [F].

Tighten screws [G] to secure the mounting plate [B] to the junction box.

Cut the excess cables with an aircraft cable cutter [H].

Note: Leave POC length of 1.5" to make the connection inside the junction box.

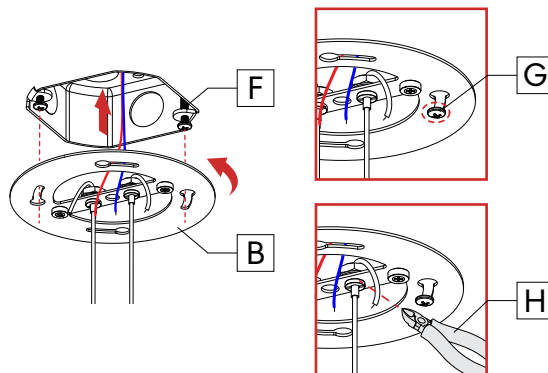

3 MAKE ELECTRICAL CONNECTIONS.

Make electrical connections between POC (power-over-aircraft cable) [C] and the remote driver feed [E].

Note: Make sure that you are connecting the negative (-) POC (as marked on the fixture with blue color and a label) to your negative wire and the positive (+) POC (as marked on the fixture with red color and a label) to your positive wire.

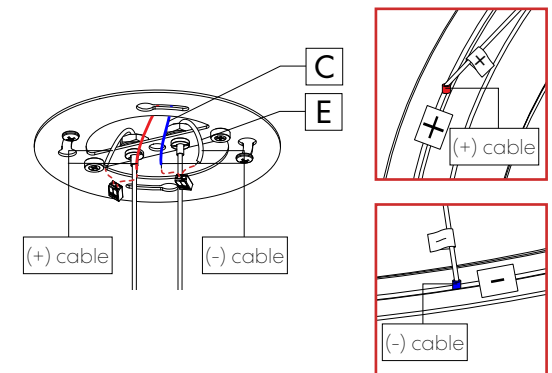

TOGO ACOUSTIX

Pendant - Remote Driver Box (RDB) - Multiple Canopies



POC (POWER-OVER-AIRCRAFT CABLE)

4 REINSTALL CANOPY.

Push all cables in the junction box, and put the canopy [A] back in place.

Cut the labels [I] off the wires.

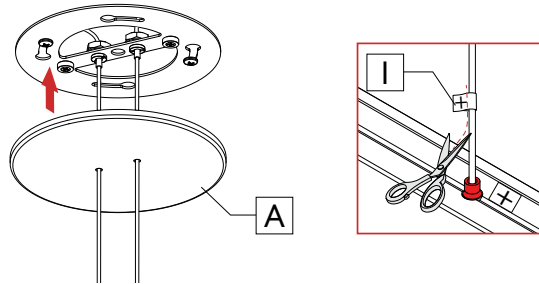

NON-POWER SIDE

1 INSTALL AIRCRAFT CABLES.

Separate the canopy [J] from the mounting plate [K].

Pass the aircraft cables [L] through the canopy [J]. Insert them into the griplocks [M] then adjust the cables [L] by pushing the feeder tube [M].

Cut the excess cables with an aircraft cable cutter [H].

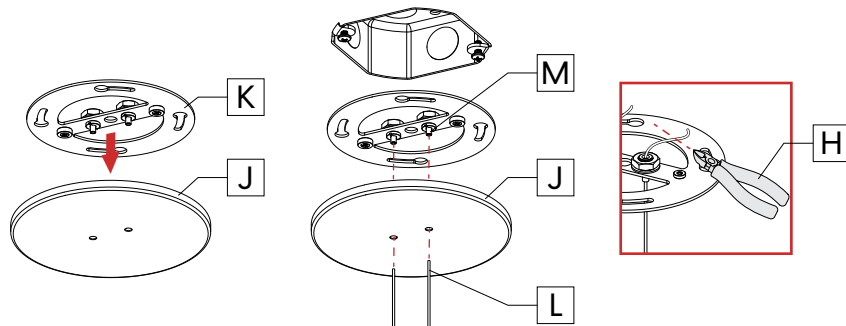

2 FIX MOUNTING PLATE AND CANOPY TO CEILING.

Mount and turn the mounting plate [K] to place on the junction box [N].

Put the canopy [J] back in place.

Tighten screws [O] to secure the mounting plate [K] to the junction box.

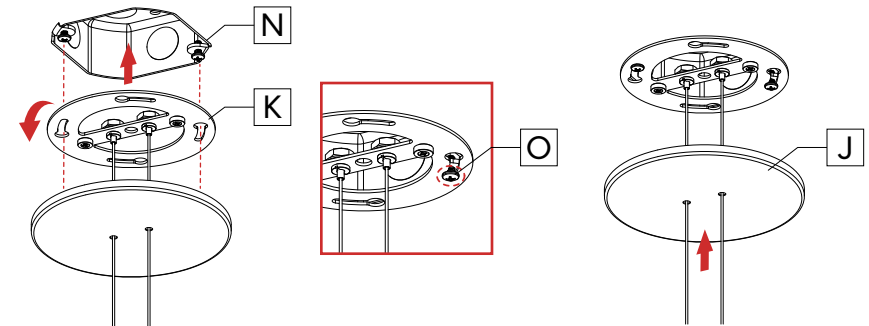

TOGO ACOUSTIX

Pendant - Remote Driver Box (RDB) - Multiple Canopies



AC (AIRCRAFT CABLE)

POWER SIDE

1 MAKE ELECTRICAL CONNECTIONS.

Install and reinforce J-box to ceiling structure. Separate the canopy [A] from the mounting plate [B].

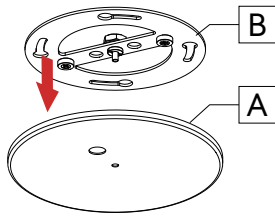

Pass the power cord [C] into the canopy [A] and make a knot. Make electrical connections between the power cord [C] and the remote driver feed [D].

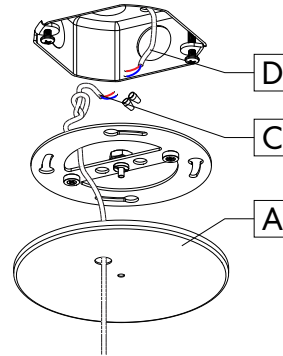

2 INSTALL AIRCRAFT CABLE.

Pass the aircraft cable [E] through the canopy [A]. Insert it into the griplock [F] then adjust the cable [E] by pushing the feeder tube [F].

Cut the excess cable with an aircraft cable cutter [G].

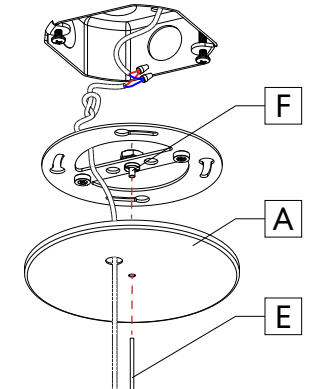
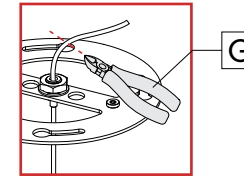

3 FIX MOUNTING PLATE TO CEILING.

Mount and turn the mounting plate [B] to place on the junction box [H].

Tighten screws [I] to secure the mounting plate [B] to the junction box.

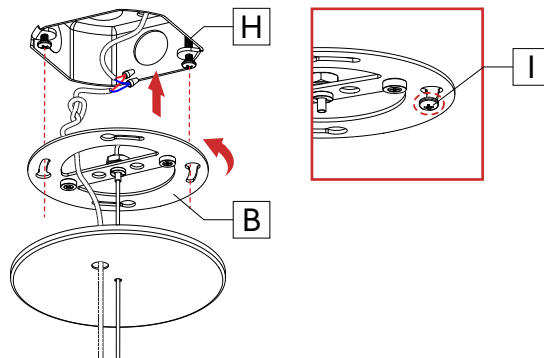

4 REINSTALL CANOPY.

Secure the power cord [C] to the aircraft cable [E] with plastic clip [J].

Put the canopy [A] back in place.

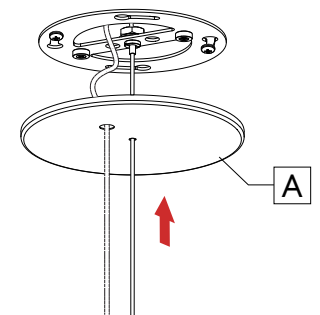
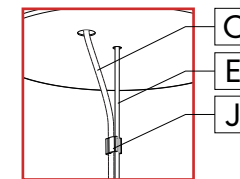

TOGO ACOUSTIX

Pendant - Remote Driver Box (RDB) - Multiple Canopies



AC (AIRCRAFT CABLE)

NON-POWER SIDE

1 INSTALL AIRCRAFT CABLE.

Separate the canopy [K] from the mounting plate [L].

Pass the aircraft cable [M] through the canopy [K]. Insert it into the griplock [N] then adjust the cable [M] by pushing the feeder tube [N].

Cut the excess cable with an aircraft cable cutter [G].

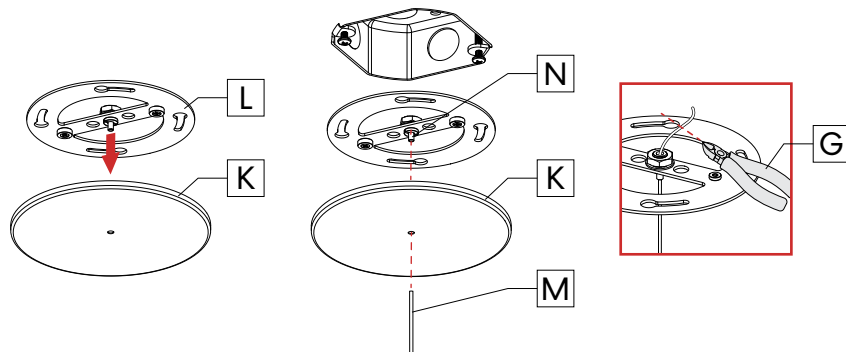

2 FIX MOUNTING PLATE AND CANOPY TO CEILING.

Mount and turn the mounting plate [L] to place on the junction box [O].

Put the canopy [K] back in place.

Tighten screws [P] to secure the mounting plate [L] to the junction box.

