

VIA 3 SEAL PERIMETER

Drywall Mud Flange

! This product must be installed in accordance with the National Electrical Code and all applicable local codes, by a person familiar with the construction and operation of the product, and the hazards involved. Proper grounding is required for safety.

Ce produit doit être installé suivant le code national de l'électricité, ainsi que tous les codes locaux applicables, par une personne familière avec la construction et le fonctionnement du produit, ainsi que tous les risques qui y sont associés. La mise à terre électrique est obligatoire pour la sécurité.

- !** Wire dimming conductors as Class 1.
- !** Fixtures with an output of 1000 lm/ft or higher must not be installed in IC conditions.
- !** Shown with shallow option and applicable to level and deep options.
- !** **Fixture must be installed before drywall ceiling.**

SINGLE FIXTURE

1 PREPARE MOUNTING LOCATION.

Prepare the area and frame around the area where the fixture is going to be installed according to the dimensions [*] in the client drawings.

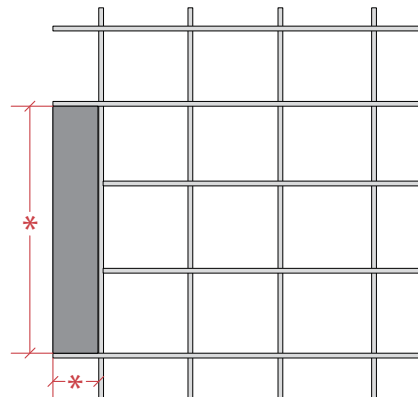

2 INSTALL J-RAIL.

Locate the J-rail [A] position according to the table below. Align with structural stud or use drywall anchors when needed.

Dimensions *

Level	1 7/16"
Shallow	2 7/16"
Deep	4 11/16"

* Bottom of J-rail to the finished ceiling plane.

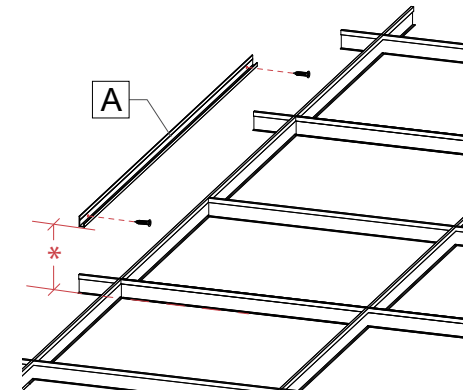
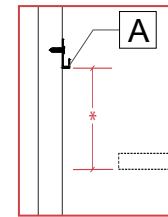

3 REMOVE LENS.

Remove the lens [B] using the provided lens tool and keep them in a safe place.

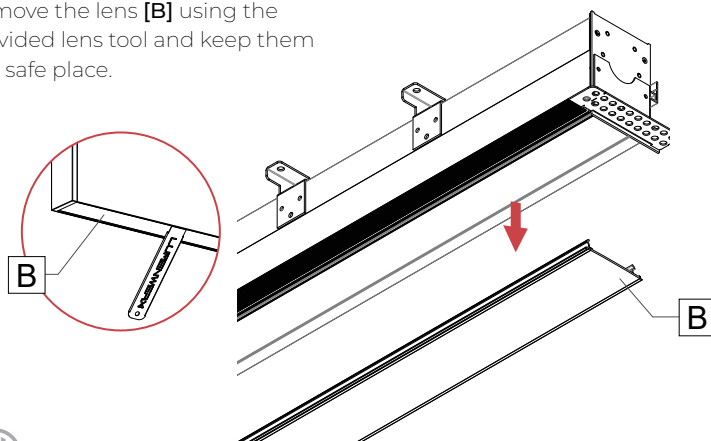

4 DISCONNECT AND REMOVE CARTRIDGE.

Disconnect LED mox connector [C] by taking a pointed object and pressing on the two tabs on the top. Unscrew and remove the cartridge [D] from the fixture. Keep the screws and plastic washers in a safe place. **Cartridge may vary.**

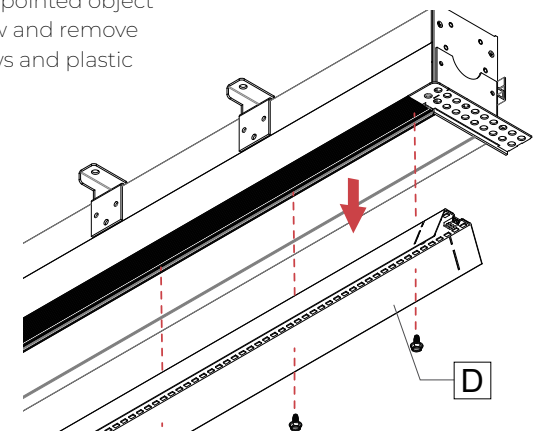
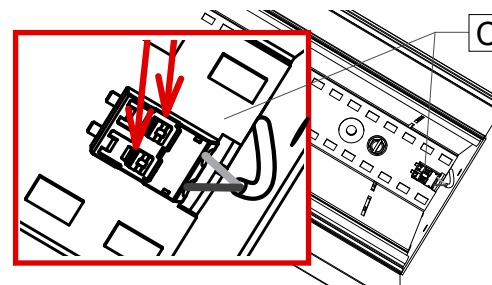

VIA 3 SEAL PERIMETER Drywall Mud Flange

5 INSTALL FIXTURE TO WALL.

Place and hook the fixture [E] in the J-rail [A].

Secure the fixture [E] in place by screwing the wall brackets [F] to the wall with drywall screws [G] (by others). Then screw [H] the wall brackets [F] to the fixture [E].

Secure the brackets [F] to the structure above if necessary (safety wires [I]/ threaded rods by others).

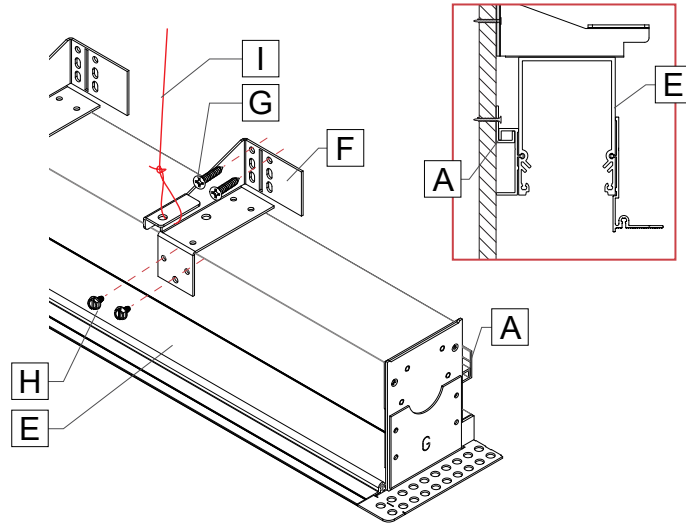

6 MAKE ELECTRICAL CONNECTIONS.

Connect the 1/2" trade size liquid-tight conduit fitting [J] (by others) to the 7/8" hole provided. Make sure the fitting is well tightened. A non-metallic liquid-tight flexible conduit system needs to be used (by others).

Make the electrical connections between power cable [K1] and the fixture cable [K2] inside the fixture using quick connectors [L].

Warning: A luminaire with more than one power supply connection means shall be connected to only one branch circuit.

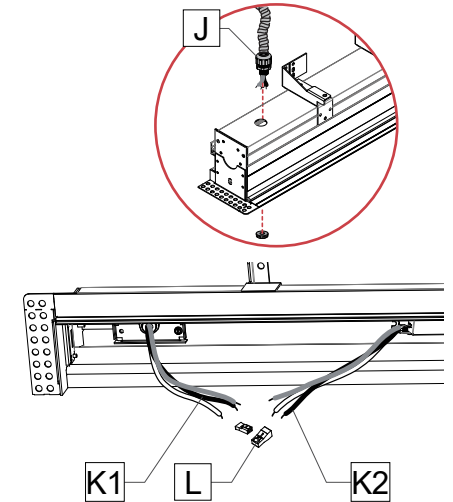

7 RECONNECT CARTRIDGE.

Reconnect the RED and BLUE wires. Reinstall the cartridge [D] by using the screws and plastic washers. **Do not apply too much pressure.**

Note: Connect blue wire into the [-] negative terminal and the red wire into the [+] positive terminal.

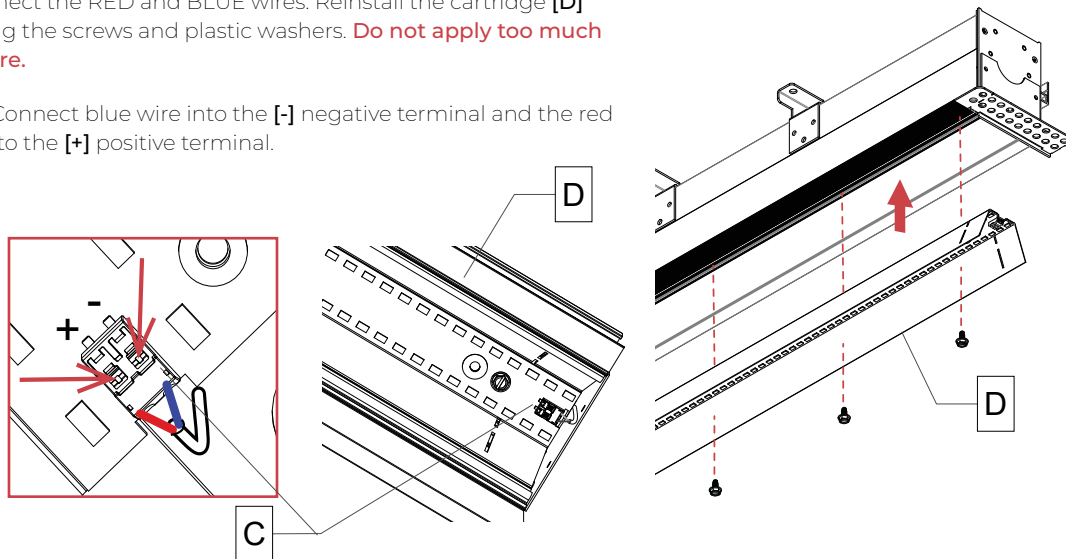

8 REINSTALL LENS.

Put the lens [B] back in place.

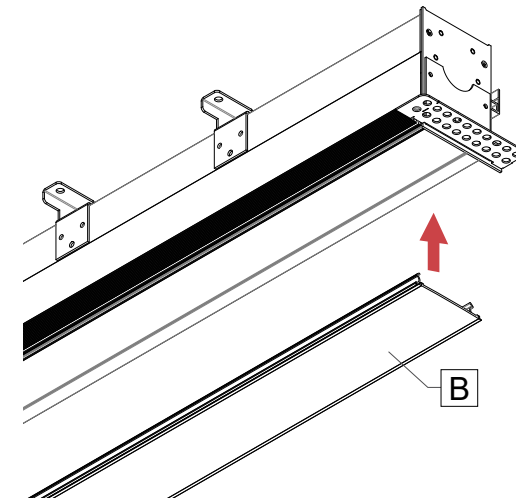

VIA 3 SEAL PERIMETER Drywall Mud Flange

9 INSTALL DRYWALL.

Install the drywall [M] to the ceiling profile.

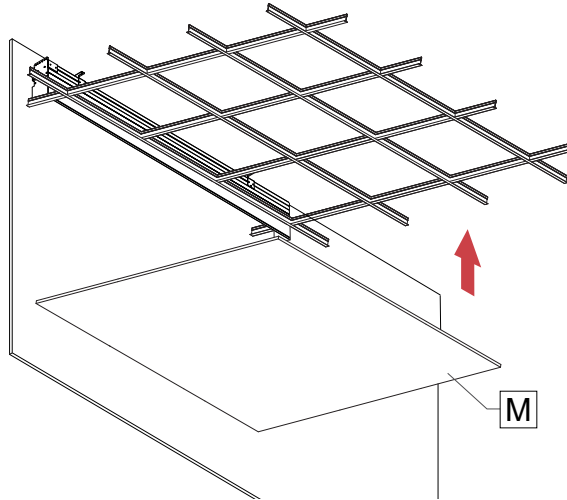

10 SECURE THE FIXTURE.

Secure the fixture [E] to the ceiling by fastening drywall screws [N] (by others) through the flanges into the ceiling. Framing [O] around the fixture is necessary for a good installation.

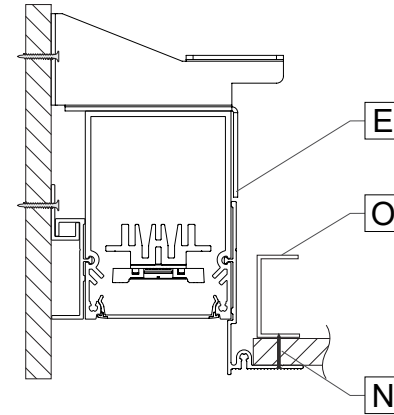

11 PLASTER OVER MUD FLANGE & FINISH.

Plaster, sand and paint over mud flange to create a smooth finish. When the paint is dry, gently remove the protective lens cover.

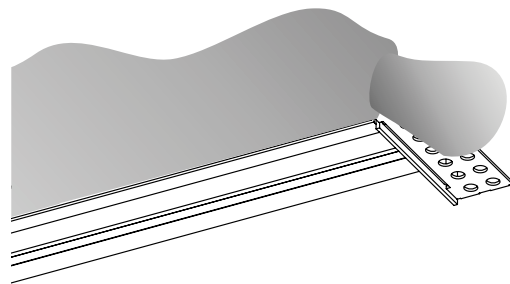

VIA 3 SEAL PERIMETER

Drywall Mud Flange

CONTINUOUS RUN

1 FOR THE FIRST FIXTURE IN THE RUN, FOLLOW STEPS **1 - 8** FROM THE SINGLE FIXTURE SECTION.

2 FOR THE SECOND FIXTURE IN THE RUN, FOLLOW STEP **2** FROM THE SINGLE FIXTURE SECTION, THEN:

WETL ONLY: FOLLOW STEPS **3** and **4** FROM THE SINGLE FIXTURE SECTION.

3 FIX BRACKET TO WALL.

Drop the fixture in the J-rail **[A]**, then attach the brackets **[F]** to the wall by screwing **[G]** (by others) the wall brackets **[F]** to the wall.

Secure the brackets **[F]** to the structure above if necessary (safety wires **[I]**/ threaded rods by others).

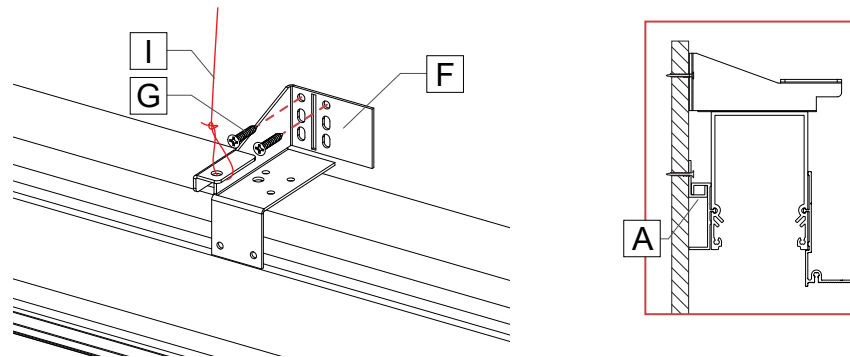

4 JOIN FIXTURES AND MAKE ELECTRICAL CONNECTIONS.

WET - Wet suitable

1. Make the wire connection between the first two sections using wire connectors **[L]**.

Number of wires may vary.

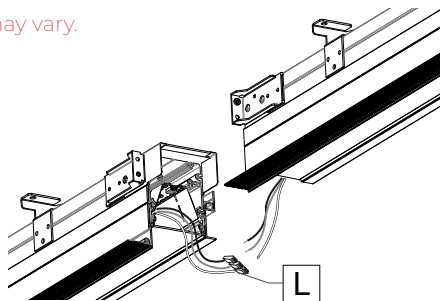

2. Push wires **[P]** inside the second fixture **[E2]**. Push the second fixture **[E2]** against the first fixture **[E]**.

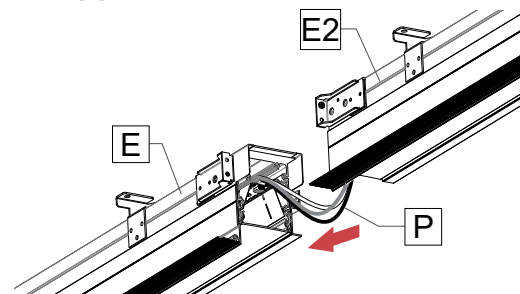

3. Screw external joiners **[Q]** to each other.

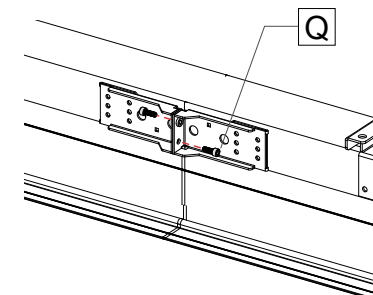

VIA 3 SEAL PERIMETER Drywall Mud Flange

WETL - Wet listed

1. Unscrew and remove screws from the internal joiner [R]. Keep them in a safe place.

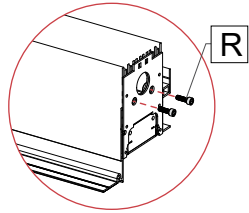

2. Push wires [P] inside the second fixture [E2] through the wire holes in the joiners. Push the second fixture [E2] against the first fixture [E].

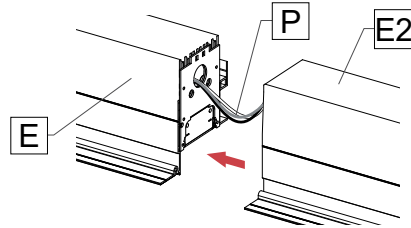

3. Reinstall the joining screws [R]. Tighten them well and make sure the joining gasket is well compressed between the two extrusions.

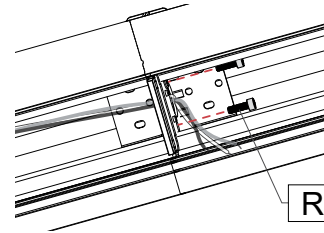

4. Make the wire connections between [E] and [E2] inside the second fixture by using quick connectors [L].

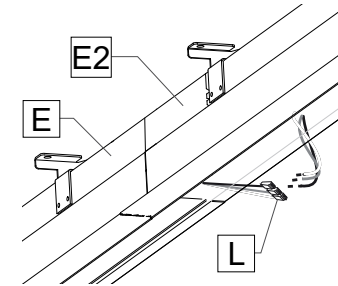

5 FIX BRACKET TO FIXTURE.

Screw [H] the wall bracket [F] to the fixture [E].

WETL ONLY:

Follow steps 7 and 8 from the single fixture section to put the cartridge and lens back.

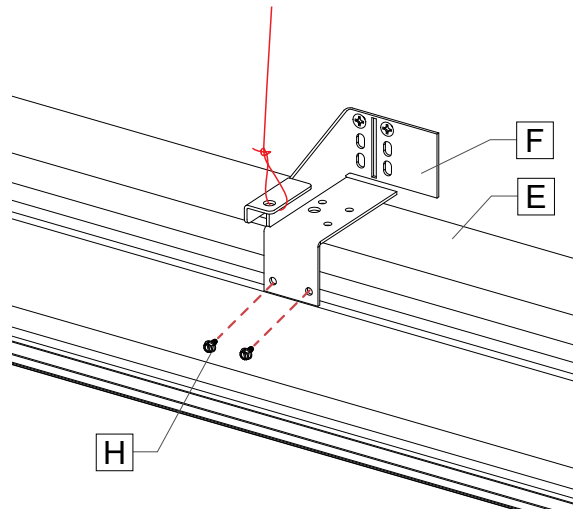

6 REPEAT STEPS 2 - 5 FROM THE CONTINUOUS RUN SECTION FOR THE REST OF THE FIXTURES IN THE RUN.

7 AFTER ALL FIXTURES ARE INSTALLED: FOLLOW STEPS 9 - 11 FROM THE SINGLE FIXTURE SECTION FOR ALL THE FIXTURES IN THE RUN.